

Retaining clamps

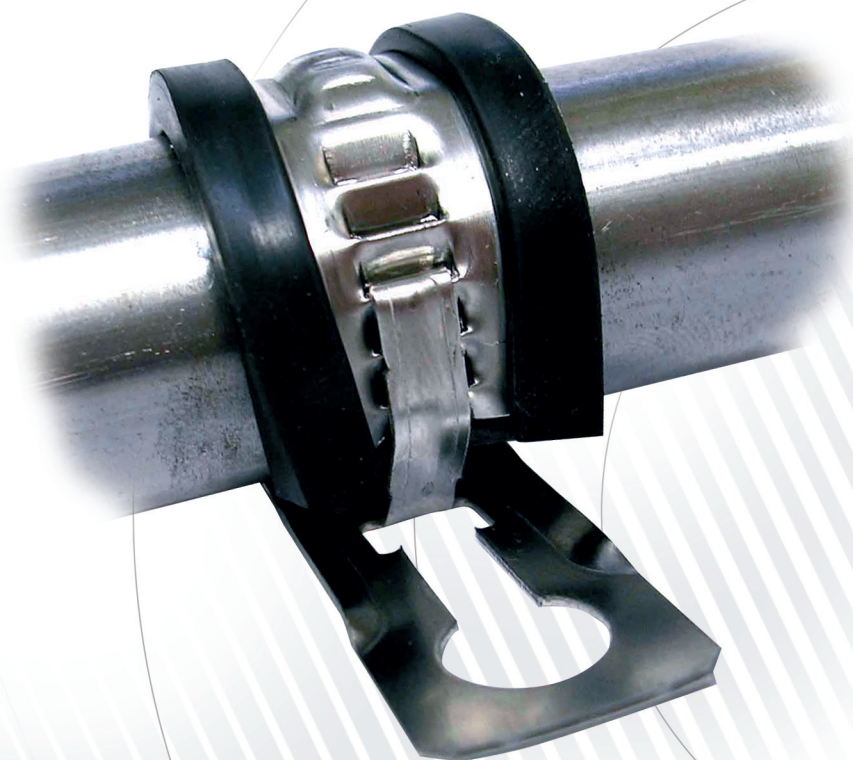

ADJUSTABLE RETAINING CLAMPS

Caillau's specific retaining clamp is made of a band with a circular part covered with a rubber cushion to receive the element to be clamped, and a clip to hold the assembly. This clamp is used to hold hoses or cables (power cords, metal hoses and pipe-ends, filters, etc.).

- Absorbs vibration for the clamped elements.
- Resists salt spray for over 1 000 hrs.
- Resists temperature (-30° to + 100°C) and "automotive" fluids.
- Manual clamping (pressing the clamp into the holding clip).
- Allows pre-tightening/positioning on the part to be clamped.
- Allows assembly of the "P" clips on the vehicle at a different stage than the assembly of the component to be retained.
- Allows unclamping of the application without having to disassemble the support.
- The same clamp can be used on applications with various diameters.
- Is reusable (under normal use conditions).
- Materials: Stainless steel band and EPDM cushion.



Référence CAILLAU / CAILLAU's reference	plage d'utilisation / utilisation range Ø d	Ø D	B	b	H	h	Ø C	E	poids / weight (gr)
55 2 000 019	16	19	52	50	29	26	6,5	0,43	6,79
55 2 000 023	19	23	55	52	34	29	8,8	0,63	11,18
55 2 000 029	25	29	61	56	39	35	8,8	0,63	14,16

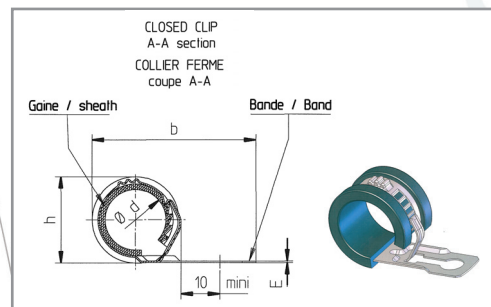
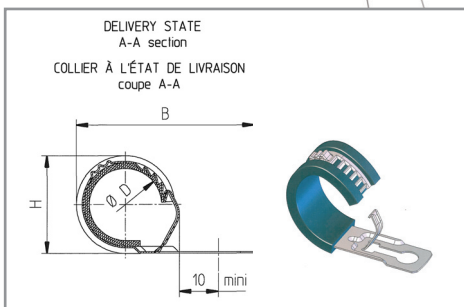

TRADITIONAL RETAINING CLAMPS

Beyond its specific products, CAILLAU also has a wide range of "P" clips, from diameter 3mm to diameter 105mm. Band widths: 9.5 and 12.7mm, as well as other widths upon request.

Materials:

- Band: stainless steel, clad steel, aluminium
- Cushion: EPDM, Silicone, FKM, ...



Example of existing references

Ø D	J	K	L	Alliage d'aluminium Aluminium alloy			Acier Stell		
				T	W	X	T	W	X
3	11,6	10,5	1,6	0,8	12,7	5,5	0,8	9,5	4,8
4	12,1	11,0							
5	12,6	11,5							
25	24,4	23,3	1,6	1,3	12,7	5,5	0,8	12,7	5,5
26	24,9	23,8							
27	25,4	24,3							
102	63,4	61,8	3,2	1,6	12,7	5,5	1,0	12,7	5,5
104	64,4	62,8							
105	64,9	63,3							

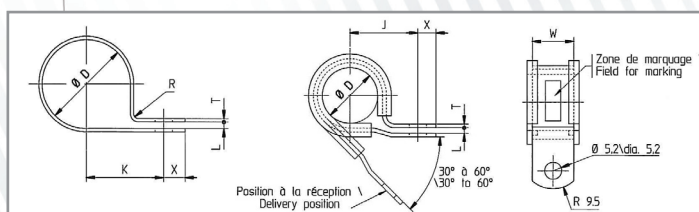

CAILLAU